

DINCEL STRUCTURAL WALLING

WATER OR LIQUID STORAGE TANKS

PATENTS

The following information presented is patented intellectual property.

COPYRIGHT

© Dincel Construction System Pty Ltd

All rights reserved. No part of the information contained in this document may be reproduced or copied in any form or by any means without written permission from Dincel Construction System Pty Ltd

DISCLAIMER

The information contained in this document is intended for the use of suitably qualified and experienced architects and engineers and other building professionals. This information is not intended to replace design calculations or analysis normally associated with the design and specification of buildings and their components. Dincel Construction System Pty Ltd accepts no liability for any circumstances arising from the failure of a specifier or user of any part of Dincel Construction System to obtain appropriate professional advice about its use and installation or from failure to adhere to the requirements of appropriate Standards and Codes of Practice, and relevant Building Codes.

PREFACE

Waterproofing is one of the most important issues for any storage tank. The life of the structure or healthy indoor environment is directly related to waterproofing.

In order to have waterproof tanks, the walls and tank base must be considered as one unit. The important components to achieve waterproof walls are:

1. DINCEL-WALLS

Tested by CSIRO under 6m head of water pressure. The following documents must be read and understood if Dincel-Wall is to be used as a waterproof tank wall.

[\(Download – Dincel Wall Waterproofing Warranty\)](#)

2. JOINT BETWEEN DINCEL-WALL AND BASE SLAB

This is the point for water leakage unless the joint is treated. The latter part of this document provides adequate information for the treatment of the Dincel-Wall and base slab joint.

3. BASE SLAB

The concrete slab will crack and leaking water will cause concrete cancer unless it is stressed by post-tensioning. This is why all base slabs in direct contact with water should have a membrane system.

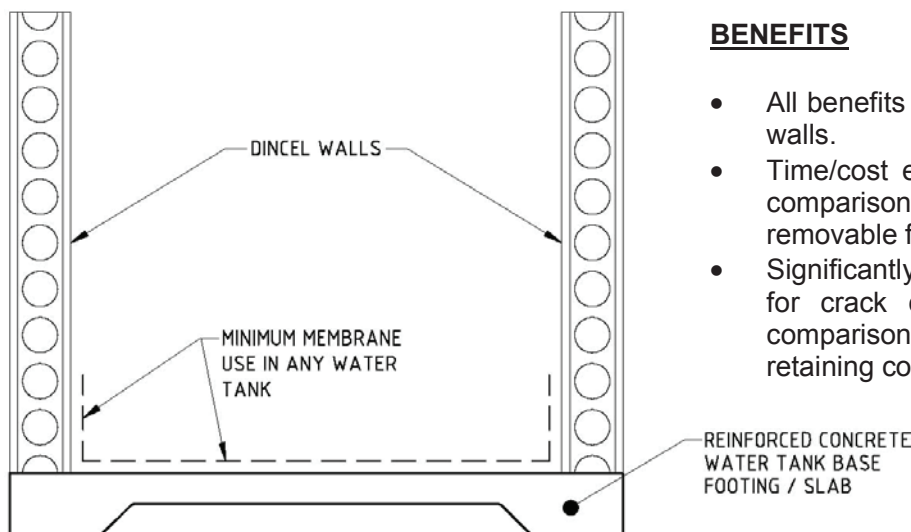

MINIMUM WATER TANK WATERPROOFING REQUIREMENT

BENEFITS

- All benefits relating to basement walls.
- Time/cost effective formwork in comparison to conventional removable formwork.
- Significantly less reinforcement for crack control purposes in comparison to in-situ water retaining concrete walls.

Note: The membrane shown may require to be extended on the rest of Dincel-Wall if installed/concrete wall joints are damaged or display bulging because of installation/concreting activities during construction. (Refer Dincel Construction Manual, Installation and Concreting Section, Items 6, 7, 9 and 13).

CASE STUDY 1 – CIRCULAR TANKS

EXAMPLE (A) 30M DIAMETER X 4M HIGH CIRCULAR TANK

This case study compares the use of Dincel Construction System with a conventionally formed method of construction for a circular liquid/water storage tank.

The storage tank for this case study is based upon the following:

GEOMETRY

- Diameter = 30m internal
- Height = 4m
- Maximum Storage Volume = 2.82ML

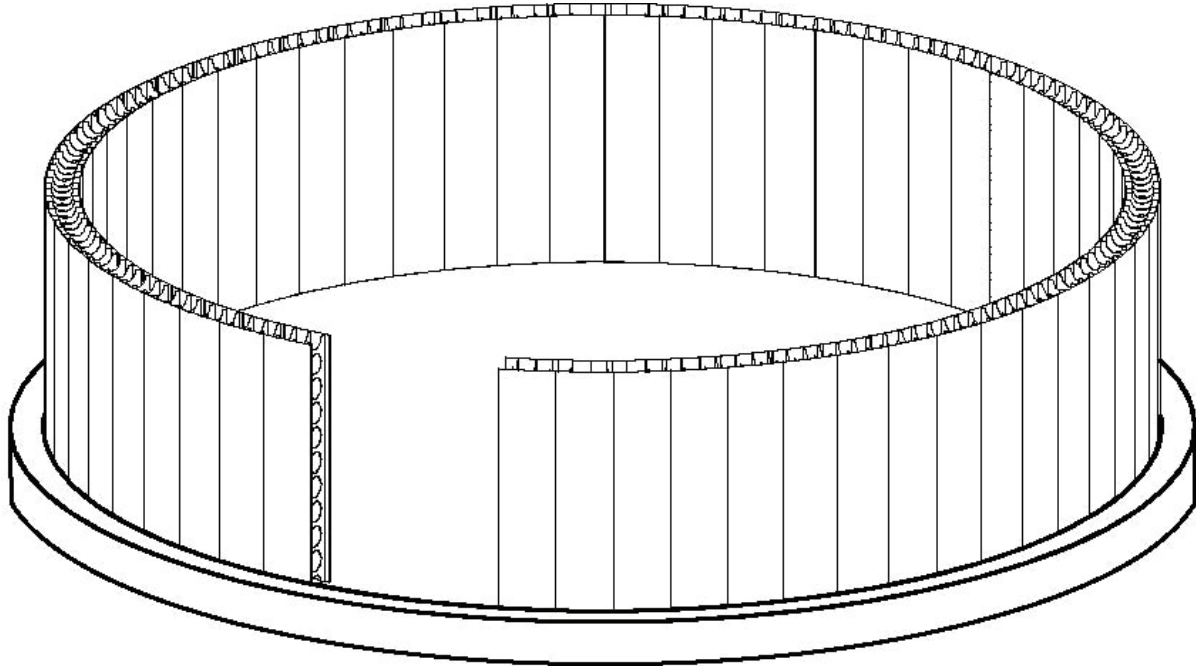

DESIGN

- Wall is hinged at base – free at top. If a ring beam at the top of the wall is provided, the design principles of Case Study 2 can be applied.
- Tank is considered in both above and below ground situations.
- Primary loading case is internal water pressure due to stored liquid.
- Liquid is in a quiescent state.
- Conventional reinforcement design in accordance with AS3735 – 2001 – Concrete Structures For Retaining Liquids.
- Exposure classification = B1 (pH of liquid > 6.5).

For the two options considered, the walls have been analysed to determine horizontal hoop stresses and vertical bending stresses due to the retained liquid and a hinged base restraint condition. The method of reinforcement to resist these stresses along with crack control provisions are outlined for each of the options as follows.

CONVENTIONALLY FORMED CONCRETE WALL

For the conventionally formed option, the calculated hoop stresses are resisted by horizontal reinforcement placed in both the inside and outside faces of the tank wall. The concrete is assumed to be cracked and therefore provides no strength when considering tensile hoop stresses. Crack widths are controlled by the provision of minimum reinforcement quantities and limiting the stress within the reinforcing bars. The vertical bending stresses are resisted by reinforcement placed in both the inside and outside faces of the wall. In the particular example we are considering for this case study, the minimum required wall thicknesses is 250mm to satisfy bending, cover and reinforcement placement requirements. The minimum cover to reinforcement is 40mm and 16mm diameter reinforcing bars have been adopted.

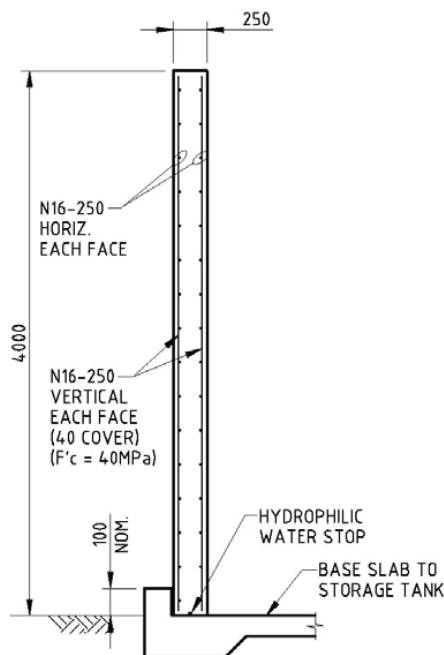

IN-SITU FORMED CONCRETE WALL

DINCEL CONSTRUCTION SYSTEM (DCS)

For the Dincel Construction System option, the construction of the tank utilises the DCS permanent polymer formwork which is filled with concrete. In the case of above ground applications the hoop stresses are resisted by 3 rows of externally installed steel bands and vertical bending stresses are resisted by vertical reinforcement in both faces between the steel bands. In the case of below ground tank applications the tensile hoop stresses are resisted by passive resistance of the soil and compacted backfill. In the empty state of inground tank the compressive hoop stresses are resisted by the concrete.

The Dincel walling system consists of a permanent polymer formwork shell which encloses concrete infill. The permanent polymer formwork has inbuilt crack inducers which provide controlled articulation of the concrete resulting in the elimination of crack control reinforcement (refer to website – waterproof walls).

The tensile capacity of 40 Mpa (average) offered by the polymer of Dincel-Form is ignored for calculation of bending reinforcement between steel bands.

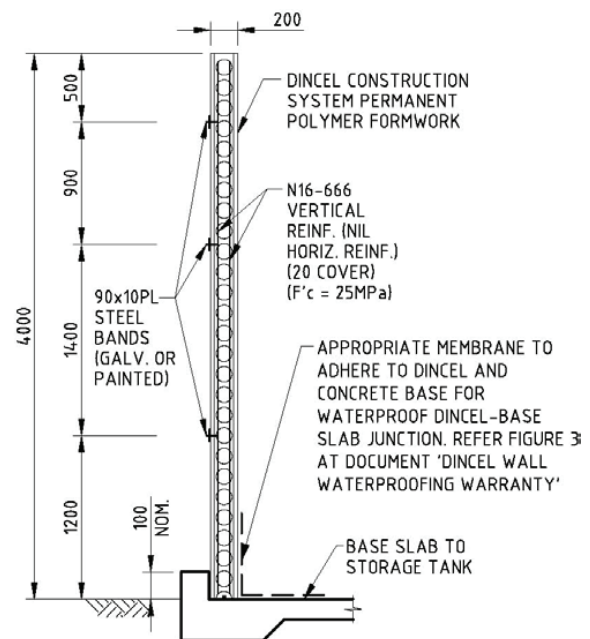

DINCEL - WALL

NOTE: OMIT EXTERNAL STEEL BANDS FOR INGROUND CONDITION

COMPARISON OF OPTIONS

The case study will compare the quantity of concrete and quantity of steel reinforcement for the two options. The results are set out in the table below.

COMPARISON OF MATERIAL QUANTITIES		
OPTION	CONCRETE VOLUME (M ³)	STEEL REINFORCEMENT (TONNES)
Conventionally formed and reinforced (above and below ground)	95 (40 Mpa)	10.1
DinCEL Construction System (above ground)	69 (25 Mpa)	3.95
DinCEL Construction System (below ground)	69 (25 Mpa)	1.8

COMMENTS AND CONCLUSION

Clearly the above summary table, which reflects the material quantities for the two options, shows a significant saving in both concrete volume and steel reinforcement tonnage.

The advantages of constructing water/liquid storage tanks utilises the DinCEL Construction System for the walls are summarised as follows:

- 27% reduction in concrete volume.
- 25 Mpa concrete is used rather than 40 Mpa.
- 60% reduction in steel reinforcement for above ground applications.
- 82% reduction in steel reinforcement for below ground applications.
- Permanent watertight tank with permanent waterproof membrane.
- Elimination of expensive curved formwork.
- Rapid erection of DinCEL Construction System formwork requiring minimal bracing.
- Unskilled labour use.
- Elimination of steel corrosion and maintenance.
- Protection against chemically aggressive ground such as acidic and saline conditions.
- All the above represent significant embodied energy and CO₂ reduction.

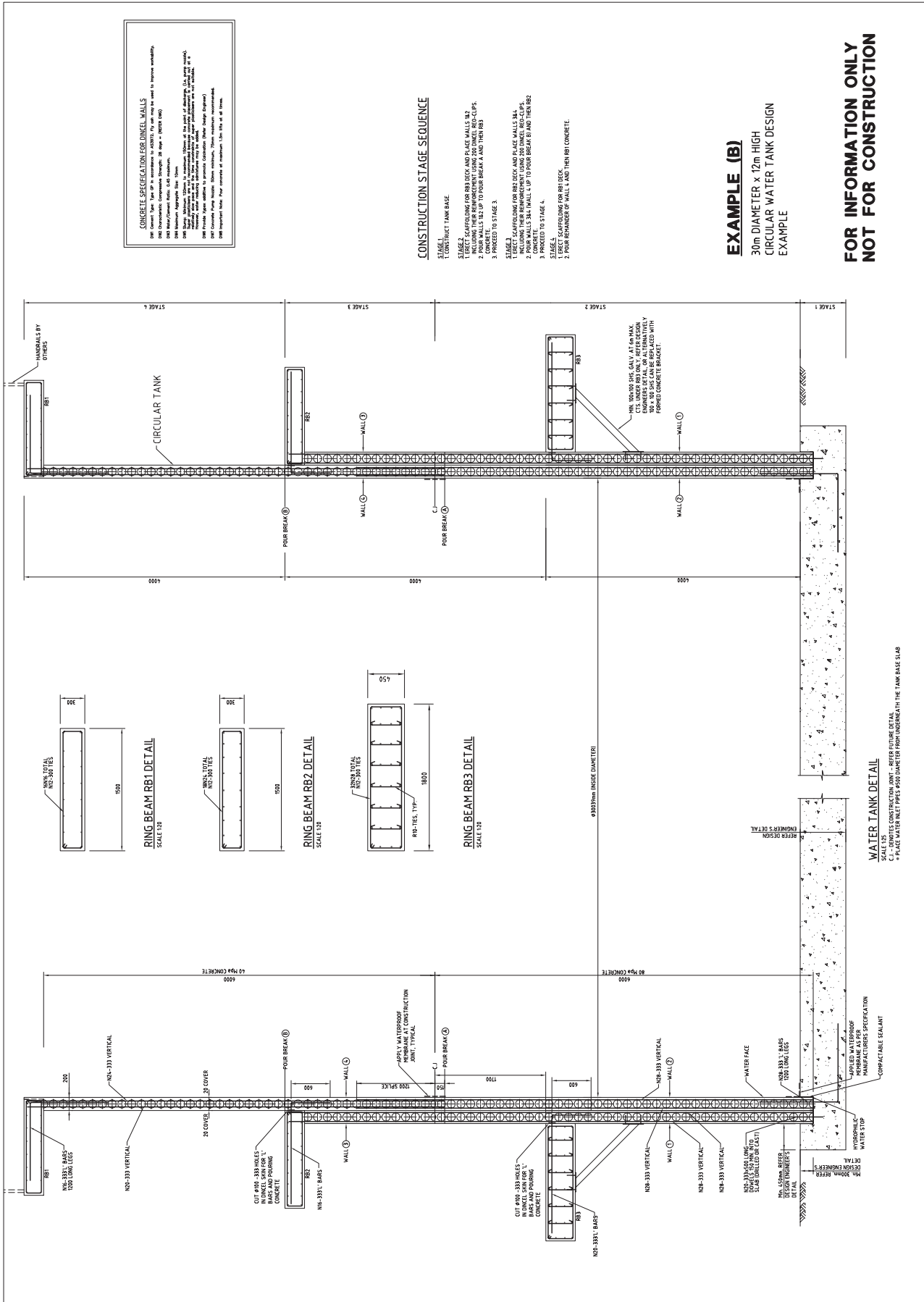

CASE STUDY 2 – RECTANGULAR TANKS

Case Study 1 demonstrates if the tank is designed to use in-situ concrete. There is a significant difference in both concrete and steel materials in comparison to Dintel-Walls.

The other equally important issue is the cost and time of the formwork installation for in-situ concrete.

The following is an example for building professionals which is most commonly used for liquid storage tanks including water tanks.

GEOMETRY

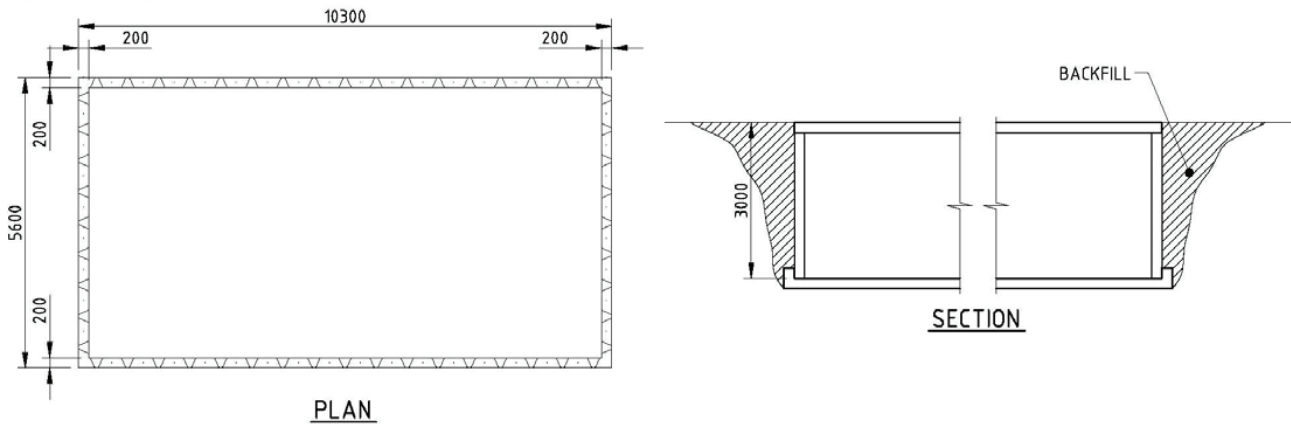

DESIGN ASSUMPTION:

The periphery of an in-ground tank is backfilled with stabilised and compacted material. This way, the tank can only be designed for earth pressure rather than water pressure. This design would only require steel reinforcement on the one wall face only which is the wall face opposite the backfilling.

If the tank surrounding is not filled with stabilised and compacted material, the presence of backfilling for design purposes should be ignored. This will result in the wall having double face reinforcement. In the majority of cases, sand backfilling with watering will be sufficient to eliminate the need for double face reinforcement.

Refer for design and construction example ([Download – Example for Ordering Dintel Profiles](#))

DETAILING ISSUES TO BE CONSIDERED WITH WATER TANKS

WALL BASE:

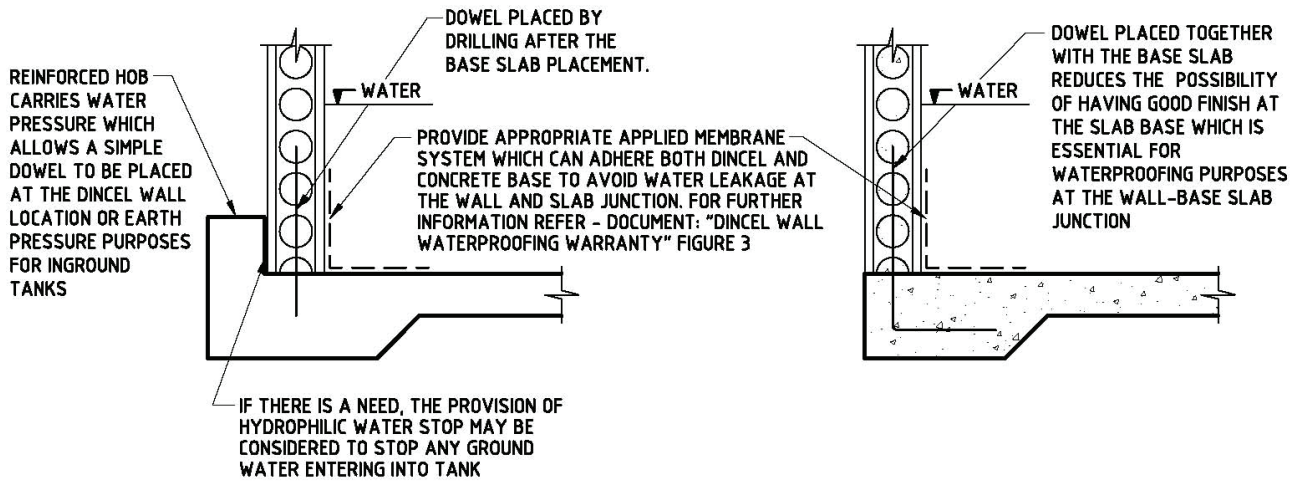

CORNERS:

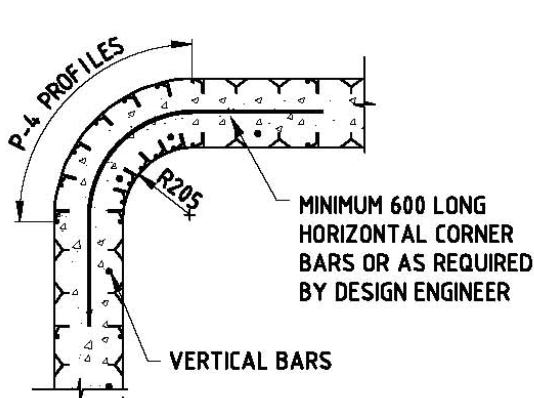

OPTION-1

R205mm - 90° CORNER

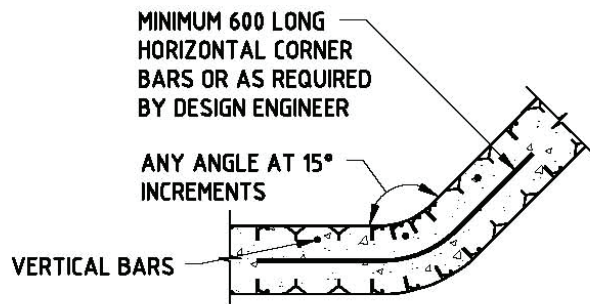

OPTION-2

ANY ANGLE IN 15° INCREMENTS

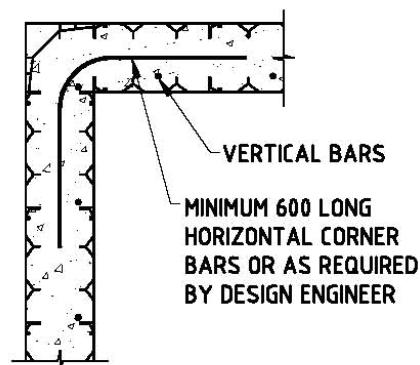
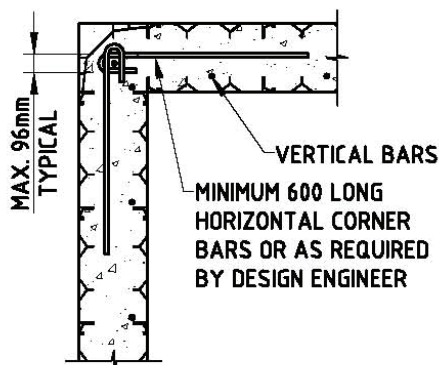

CORNER DETAILS AT 200MM THICK BASEMENT WALLS